

APPLICATION

Cesco Products models 30S and 30D curtain fire dampers are approved for use in walls, floors and partitions of 3 hours or more where the centerline of the blade stack is contained within the depth of the wall, floor or partition. Model 30S dampers are classified for use in static HVAC systems that are automatically shut down in the event of a fire. Model 30D dampers are classified for use in dynamic HVAC systems that remain operational during a fire event.

RATINGS

UL 555 Fire Resistance Rating (models 30S and 30D)

Fire Rating: 3 hours

Dynamic Closure Rating (model 30D only)

Maximum Velocity: 4000 fpm (20.3 m/s)

Maximum Pressure: 8 in. wg (2 kPa)

*see page 2 for complete list of ratings

Construction	Standard	Optional
Frame Material	Galvanized Steel	-
Frame Depth	4 7/8" (124 mm)	-
Blade Material	Galvanized Steel	-
Closure Springs	Stainless Steel	-
Fusible Link	165°F (74°C)	212°F (100°C)
Mounting	Vertical (30SV / 30DV)	Horizontal (30SH / 30DH)

Optional Features

- Sleeves of various depths and thickness - See page 3
- B-Style and C-Style Transitions - See pages 4-11
- Pressure Drop Data - See SD-CFDAP
- Tab-lock Retaining Angles - see SI-TLRA
- Flanged duct connections - See SI-ULFDC
- PK1202 Position Indication - See SI-PK1202
- Pull Ring - see SI-PULLRING
- Security Bars - see SD-SB
- X-style frame w/ integral sleeve - see SI-X-STYLE

Installation Methods

- Standard Installation - see II-FD-3
- Fire resistant duct assembly - see SI-FAPN
- Corrugated decking - see SI-DECKING
- Sleeve extensions - see SI-SLVEXT
- Retaining angle or flange under gypsum wallboard - see SI-FUGWB
- Flanged Duct Connection - SI-ULFDC
- Caulking - SI-CAULK

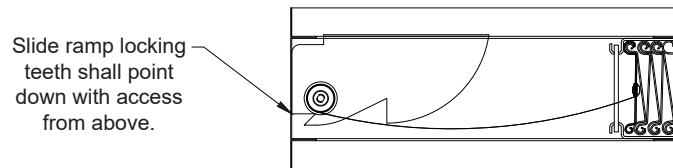

Open Position
(30SH or 30DH)

UNDERWRITERS LABORATORIES INC.®
 CLASSIFIED DYNAMIC FIRE DAMPER
 CLASSIFIED STATIC FIRE DAMPER

FILE # R6462

This fire damper meets the construction and performance requirements of:

- Underwriters Laboratories Inc. Standard 555
- National Fire Protection Association Standards 80, 90A, 101
- ICC's International Building Code
- California State Fire Marshal Listing #3225-1329:100
- Underwriters Laboratories Inc. approved for dual direction airflow.
- Underwriters Laboratories Inc. classified for use in fire resistive ratings of 3 hours or more.

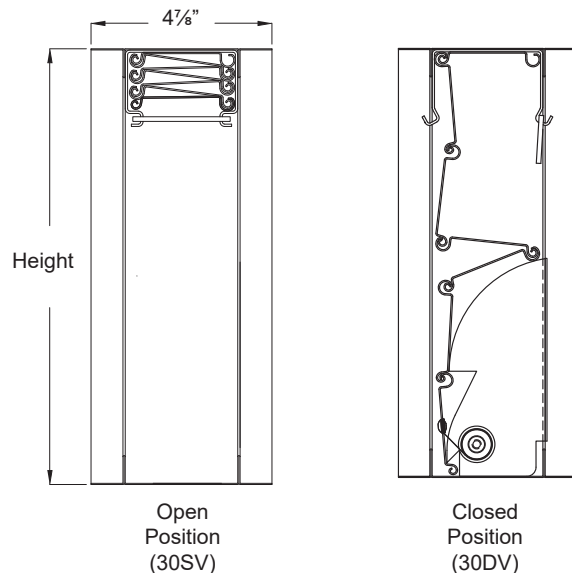
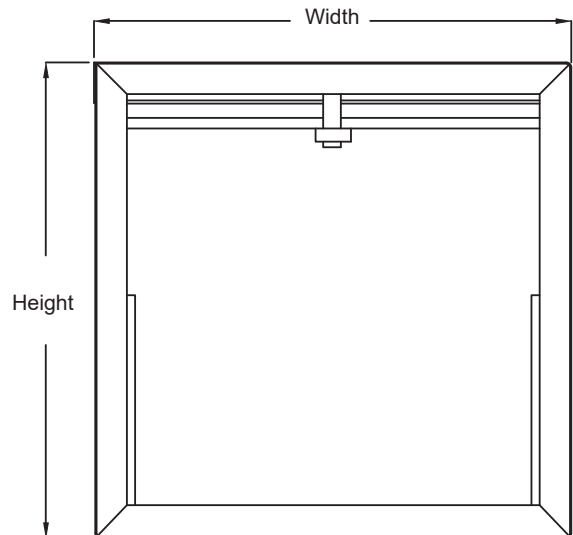

In the interest of product development, Cesco Products reserves the right to make changes without notice.

MAX SIZE LIMITATIONS

Static Dampers

Horizontal Mount		
Model #	Max Single Panel	Max Assembly
30SA	48"W x 48"H	72"W x 36"H
30SB	48"W x 43"H	72"W x 32"H
30SC	46"W x 42"H	70"W x 30"H

Vertical Mount		
Model #	Max Single Panel	Max Assembly
30SA	36"W x 36"H	72"W x 72"H
30SB	36"W x 32"H	72"W x 68"H
30SC	34"W x 31"H	70"W x 67"H

Dynamic Dampers

Horizontal Mount (2000 fpm, 4 in .w.g.)		
Model #	Max Single Panel	Max Assembly
30DA	24"W x 24"H	72"W x 36"H
	18"W x 36"H	
30DB	24"W x 20"H	72"W x 31"H
	18"W x 31"H	
30DC	22"W x 19"H	70"W x 30"H
	16"W x 30"H	

Vertical Mount (2000 fpm, 4 in .w.g.)		
Model #	Max Single Panel	Max Assembly
30DA	36"W x 36"H	72"W x 48"H
		48"W x 72"H
		120"W x 24"H
30DB	36"W x 32"H	72"W x 46"H
		48"W x 69"H
		120"W x 21"H
30DC	34"W x 31"H	70"W x 43"H
		46"W x 67"H
		118"W x 20"H

Horizontal Mount (2000 fpm, 8 in .w.g.)		
Model #	Max Single Panel	Max Assembly
30DA	18"W x 36"H	36"W x 36"H
30DB	18"W x 31"H	36"W x 31"H
30DC	16"W x 30"H	34"W x 30"H

Vertical Mount (2000 fpm, 8 in .w.g.)		
Model #	Max Single Panel	Max Assembly
30DA	24"W x 24"H	72"W x 48"H
		48"W x 72"H
		120"W x 24"H
30DB	24"W x 21"H	72"W x 46"H
		48"W x 69"H
		120"W x 21"H
30DC	22"W x 20"H	70"W x 45"H
		46"W x 68"H
		118"W x 20"H

Horizontal Mount (4000 fpm, 4 in .w.g.)		
Model #	Max Single Panel	Max Assembly
30DA	18"W x 36"H	36"W x 36"H
30DB	18"W x 31"H	36"W x 31"H
30DC	16"W x 30"H	34"W x 30"H

Vertical Mount (4000 fpm, 4 in .w.g.)		
Model #	Max Single Panel	Max Assembly
30DA	24"W x 24"H	-
	18"W x 36"H	
30DB	24"W x 21"H	-
	18"W x 32"H	
30DC	22"W x 20"H	-
	16"W x 31"H	

Vertical Mount (4000 fpm, 8 in .w.g.)		
Model #	Max Single Panel	Max Assembly
30DA	24"W x 24"H	-
30DB	24"W x 21"H	-
30DC	22"W x 20"H	-

Factory Mounted Sleeve Option

Cesco Products models 30S and 30D dampers are available with factory sleeves. Order sizes reflect the OD of the damper frame and do not include the sleeve thickness. Dampers can be provided exact size or with a 1/4" undercut (standard). Consideration must be given to sleeve thickness when determining opening and/or damper size; refer to II-FD-3 for more details. Sleeves are galvanized steel and are available in thickness ranging from 20 ga. (width and height must both be 84" or less for 20 ga. sleeves) through 10 ga. and depths up to 48" (wall depth must accommodate such that duct connections do not exceed more than 6" (or 16" if access door is used) beyond the face of the barrier.

When ordering, damper will be centered in depth of sleeve unless otherwise noted. If damper is to be installed in a location other than being centered in the sleeve depth, provide the setback distance from the end of the sleeve to the edge of the frame on the side opposite the slide ramp locking teeth so as to allow for the blades to be pushed away and disengaged from the blade lock. When access from this side is not available, the pull ring option (see SI-PULLRING) can be used to assist with pulling blades away from locking teeth.

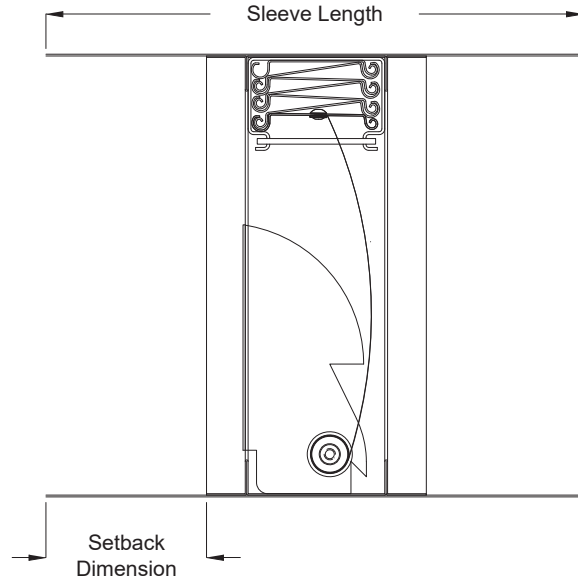

Sleeve Construction

Depending on the sleeve thickness that has been ordered, the sleeve will be fabricated in one of three styles.

- Style #1 (two piece overlap) is used for 20 ga. - 14 ga. when width + height + 1.5 <= 100.
- Style #2 (four piece overlap) is used for 20 ga. - 14 ga. when width + height + 1.5 > 100.
- Style #3 (four piece welded) is used for all 10 ga. and 12 ga. sleeves.

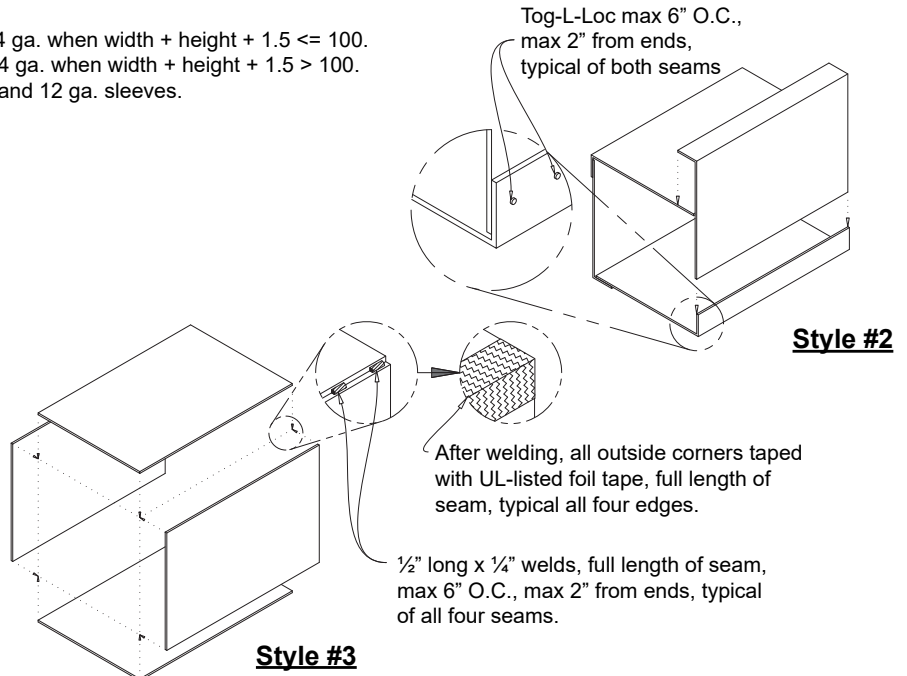
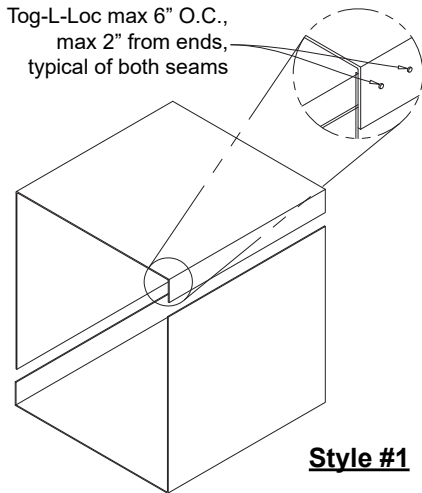

Factory Mounted Transitions

Cesco Products models 30S and 30D can be ordered with B or C style transitions. Without transitions the models are referred to as 30SA and 30DA. With transitions the models are referred to as 30SB, 30SC, 30DB and 30DC. Transitions serve two purposes; they can be used to transition to round or oval duct, or they can be used to eliminate the blades and/or frame members from the airstream to provide for better air performance. A B-style transition eliminates the blade stack from the airstream, whereas a C-style transition eliminates the blade stack as well as the jambs and sill from the airstream. A rectangular or square B-style transition is referred to as a B-pan; an oval or round B-Style transition is referred to as a cap/collar transition. All C-style transitions are referred to as cap/collar transitions. Both cap/collar and B-pan transitions can be fitted to a factory mounted sleeve, or directly to the damper frame.

B-Pan Transitions - used to eliminate the blade stack from the airstream; constructed from 20 ga.

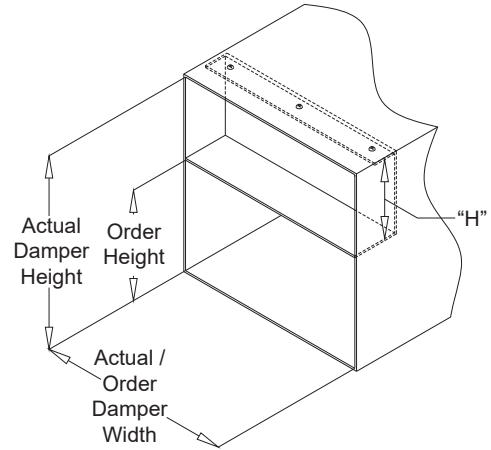
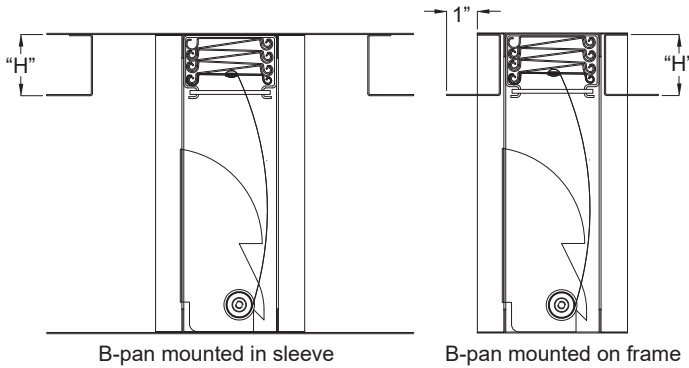

"H" = head height/blade stack height, see following tables on pages 5 - 7.

B-Style Cap/Collar Transitions - used to eliminate the blade stack from the airstream and transition to a different shape. Caps are constructed from 20 ga., collars are constructed from 24 ga. Collars are undersized to fit inside adjoining duct. See page 8 for collar details.

Note: Factory supplied round and oval transitions provide the breakaway connections when certain criteria are met, refer to II-FD-3 for complete details

Note: Order Width & Height = OD of frame only and do not include sleeve thickness

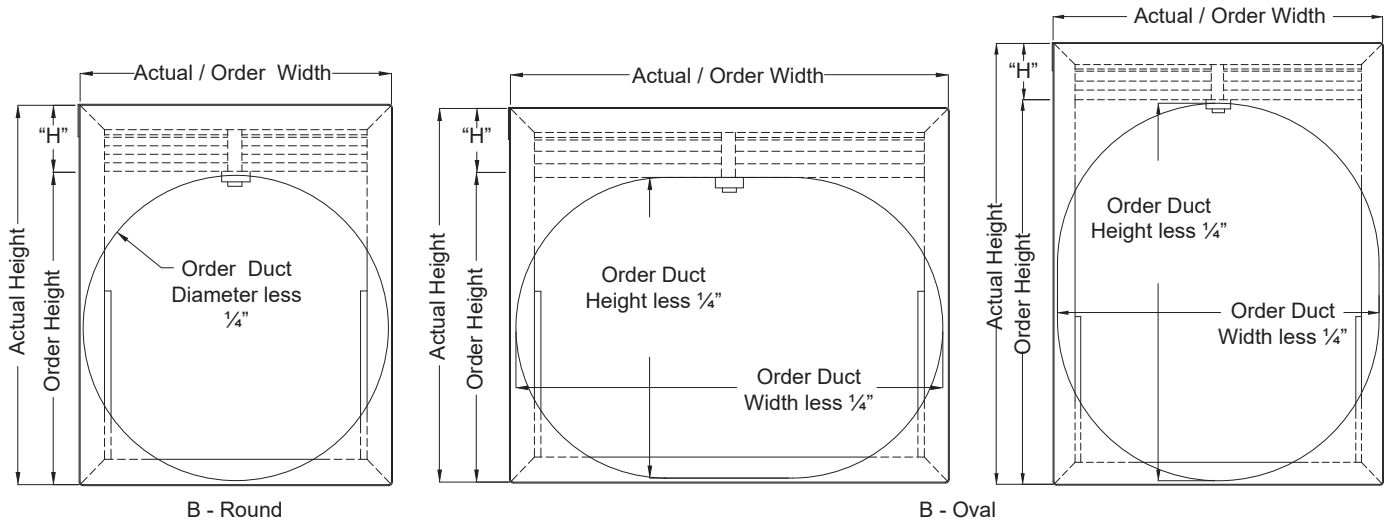

B-STYLE TRANSITION SIZING CHART

30SH: max single panel 48"W x 48"H, max panel in assembly 36"W x 36"H

30SV: max single panel 36"W x 36"H

30SH (Single Panel)

30SH (Multi Panel) & 30SV

30SV

Damper Sizing - B-Style Transitions					
Duct Height	Assy. Height	# Panels High	Panel Height	"H"	# Blades
4"	-	1	6"	2"	4
5"	-	1	7"	2"	4
6"	-	1	8"	2"	5
7"	-	1	9"	2"	5
8"	-	1	10"	2"	5
9"	-	1	11"	2"	6
10"	-	1	12"	2"	6
11"	-	1	13"	2"	6
12"	-	1	14"	2"	7
13"	-	1	15"	2"	7
14"	-	1	16"	2"	8
15"	-	1	17"	2"	8
16"	-	1	18"	2"	8
17"	-	1	19"	2"	9
18"	-	1	20"	2"	9
19"	-	1	22"	3"	10
20"	-	1	23"	3"	10
21"	-	1	24"	3"	11
22"	-	1	25"	3"	11
23"	-	1	26"	3"	11
24"	-	1	27"	3"	12
25"	-	1	28"	3"	12
26"	-	1	29"	3"	13
27"	-	1	30"	3"	13
28"	-	1	31"	3"	13
29"	-	1	33"	4"	14
30"	-	1	34"	4"	15
31"	-	1	35"	4"	15
32"	-	1	36"	4"	15
33"	-	1	37"	4"	16
34"	-	1	38"	4"	16
35"	-	1	39"	4"	17
36"	-	1	40"	4"	17
37"	-	1	41"	4"	17
38"	-	1	42"	4"	18
39"	-	1	43"	4"	18
40"	-	1	44"	4"	18
41"	-	1	46"	5"	19
42"	-	1	47"	5"	20
43"	-	1	48"	5"	20

Damper Sizing - B-Style Transitions					
Duct Height	Assy. Height	# Panels High	Panel Height	"H"	# Blades
4"	-	1	6"	2"	4
5"	-	1	7"	2"	4
6"	-	1	8"	2"	5
7"	-	1	9"	2"	5
8"	-	1	10"	2"	5
9"	-	1	11"	2"	6
10"	-	1	12"	2"	6
11"	-	1	13"	2"	6
12"	-	1	14"	2"	7
13"	-	1	15"	2"	7
14"	-	1	16"	2"	8
15"	-	1	17"	2"	8
16"	-	1	18"	2"	8
17"	-	1	19"	2"	9
18"	-	1	20"	2"	9
19"	-	1	22"	3"	10
20"	-	1	23"	3"	10
21"	-	1	24"	3"	11
22"	-	1	25"	3"	11
23"	-	1	26"	3"	11
24"	-	1	27"	3"	12
25"	-	1	28"	3"	12
26"	-	1	29"	3"	13
27"	-	1	30"	3"	13
28"	-	1	31"	3"	13
29"	-	1	33"	4"	14
30"	-	1	34"	4"	15
31"	-	1	35"	4"	15
32"	-	1	36"	4"	15
33"	35"	2	17.5"	2"	16
34"	36"	2	18"	2"	16
35"	37"	2	18.5"	2"	18
36"	38"	2	19"	2"	18
37"	39"	2	19.5"	2"	18
38"	41"	2	20.5"	3"	20
39"	42"	2	21"	3"	20
40"	43"	2	21.5"	3"	20
41"	44"	2	22"	3"	20
42"	45"	2	22.5"	3"	22
43"	46"	2	23"	3"	22
44"	47"	2	23.5"	3"	22

Damper Sizing - B-Style Transitions					
Duct Height	Assy. Height	# Panels High	Panel Height	"H"	# Blades
45"	48"	2	24"	3"	22
46"	49"	2	24.5"	3"	22
47"	50"	2	25"	3"	22
48"	51"	2	25.5"	3"	22
49"	52"	2	26"	3"	24
50"	53"	2	26.5"	3"	24
51"	54"	2	27"	3"	24
52"	55"	2	27.5"	3"	24
53"	56"	2	28"	3"	24
54"	57"	2	28.5"	3"	26
55"	58"	2	29"	3"	26
56"	59"	2	29.5"	3"	26
57"	60"	2	30"	3"	26
58"	61"	2	30.5"	3"	26
59"	62"	2	31"	3"	26
60"	64"	2	31.5"	4"	28
61"	65"	2	32.5"	4"	28
62"	66"	2	33"	4"	28
63"	67"	2	33.5"	4"	30
64"	68"	2	34"	4"	30
65"	69"	2	34.5"	4"	30
66"	70"	2	35"	4"	30
67"	71"	2	35.5"	4"	30
68"	72"	2	36"	4"	30

B-STYLE TRANSITION SIZING CHART

30DH

Max Panel 24"W x 24"H
or 18"W x 36"H

Damper Sizing - B-Style Transition					
Duct Height	Assy. Height	# Panels High	Panel Height	"H"	# Blades
4"	-	1	6"	2"	7
5"	-	1	7"	2"	8
6"	-	1	8"	2"	8
7"	-	1	9"	2"	9
8"	-	1	11"	3"	10
9"	-	1	12"	3"	10
10"	-	1	13"	3"	11
11"	-	1	14"	3"	11
12"	-	1	15"	3"	12
13"	-	1	16"	2"	12
14"	-	1	17"	3"	13
15"	-	1	18"	2"	13
16"	-	1	19"	3"	14
17"	-	1	20"	3"	14
18"	-	1	21"	2"	15
19"	-	1	22"	3"	15
20"	-	1	24"	4"	16
21"	-	1	25"	4"	17
22"	-	1	26"	4"	17
23"	-	1	27"	4"	18
24"	-	1	28"	4"	18
25"	-	1	29"	4"	19
26"	-	1	30"	4"	19
27"	-	1	31"	4"	20
28"	-	1	33"	5"	21
29"	-	1	34"	5"	21
30"	-	1	35"	5"	21
31"	-	1	36"	5"	21

30DV - Duct Height ≤ 36 inches

Max 36"W x 36"H single panel,
Max 18"W x 36"H panel in assembly

Damper Sizing - B-Style Transition					
Duct Height	Assy. Height	# Panels High	Panel Height	"H"	# Blades
4"	-	1	6"	2"	4
5"	-	1	7"	2"	5
6"	-	1	8"	2"	5
7"	-	1	9"	2"	6
8"	-	1	10"	2"	6
9"	-	1	11"	2"	6
10"	-	1	12"	2"	7
11"	-	1	13"	2"	7
12"	-	1	14"	2"	8
13"	-	1	15"	2"	8
14"	-	1	16"	2"	8
15"	-	1	17"	2"	9
16"	-	1	18"	2"	9
17"	-	1	19"	2"	9
18"	-	1	20"	2"	10
19"	-	1	21"	2"	10
20"	-	1	23"	3"	11
21"	-	1	24"	3"	12
22"	-	1	25"	3"	12
23"	-	1	26"	3"	13
24"	-	1	27"	3"	13
25"	-	1	28"	3"	13
26"	-	1	29"	3"	14
27"	-	1	30"	3"	14
28"	-	1	32"	4"	15
29"	-	1	33"	4"	15
30"	-	1	34"	4"	16
31"	-	1	35"	4"	16
32"	-	1	36"	4"	17

B-STYLE TRANSITION SIZING CHART

30DV - Duct Height > 36 inches

Max 24"W x 24"H panel in assembly

Damper Sizing - B-Style Transition					
Duct Height	Assy. Height	# Panels High	Panel Height	"H"	# Blades
33"	35"	2	17.5"	2"	18
34"	36"	2	18"	2"	18
35"	37"	2	18.5"	2"	18
36"	38"	2	19"	2"	18
37"	39"	2	19.5"	2"	20
38"	41"	2	20.5"	3"	20
39"	42"	2	21"	3"	20
40"	43"	2	21.5"	3"	22
41"	44"	2	22"	3"	22
42"	45"	2	22.5"	3"	22
43"	46"	2	23"	3"	22
44"	47"	2	23.5"	3"	24
45"	48"	2	24"	3"	24
46"	48"	3	16"	2"	24
47"	49"	3	16.3"	2"	27
48"	50"	3	16.7"	2"	27
49"	51"	3	17"	2"	27
50"	52"	3	17.3"	2"	27
51"	53"	3	17.7"	2"	27
52"	54"	3	18"	2"	27
53"	55"	3	18.3"	2"	27
54"	56"	3	18.7"	2"	27
55"	57"	3	19"	2"	27
56"	58"	3	19.3"	2"	30
57"	59"	3	19.7"	2"	30
58"	61"	3	20.3"	3"	30
59"	62"	3	20.7"	3"	30
60"	63"	3	21.0"	3"	30
61"	64"	3	21.3"	3"	33
62"	65"	3	21.7"	3"	33
63"	66"	3	22"	3"	33
64"	67"	3	22.3"	3"	33
65"	68"	3	22.7"	3"	33
66"	69"	3	23"	3"	33
67"	70"	3	23.3"	3"	36
68"	71"	3	23.7"	3"	36
69"	72"	3	24"	3"	36

C-Style Cap/Collar Transitions - used to eliminate the blade stack and frame from the airstream and transition to a different shape; caps are constructed from 20 ga., collars are constructed from 24 ga.

Note: Factory supplied round and oval transitions provide the breakaway connections when certain criteria are met, refer to II-FD-3 for complete details.

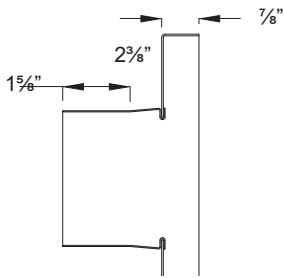
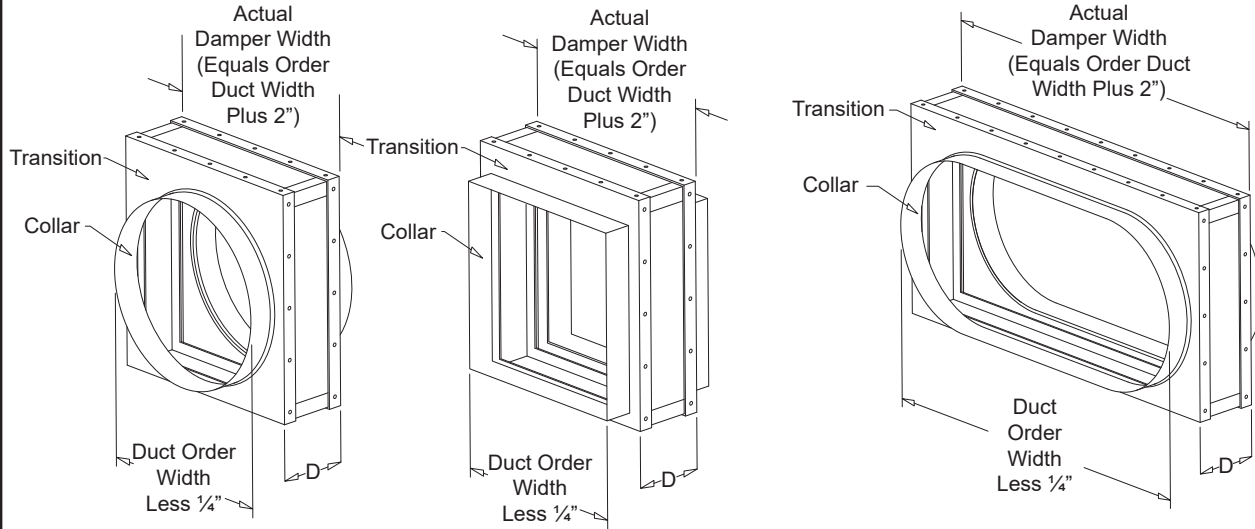

Round/Oval Collar Detail

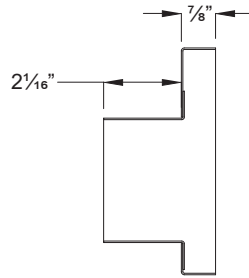

Square/Rectangular Collar Detail

D = 5" when ordered without sleeve.
 D = sleeve depth + 1/8" when ordered with sleeve
 (Refer to Page 3 for sleeve details)

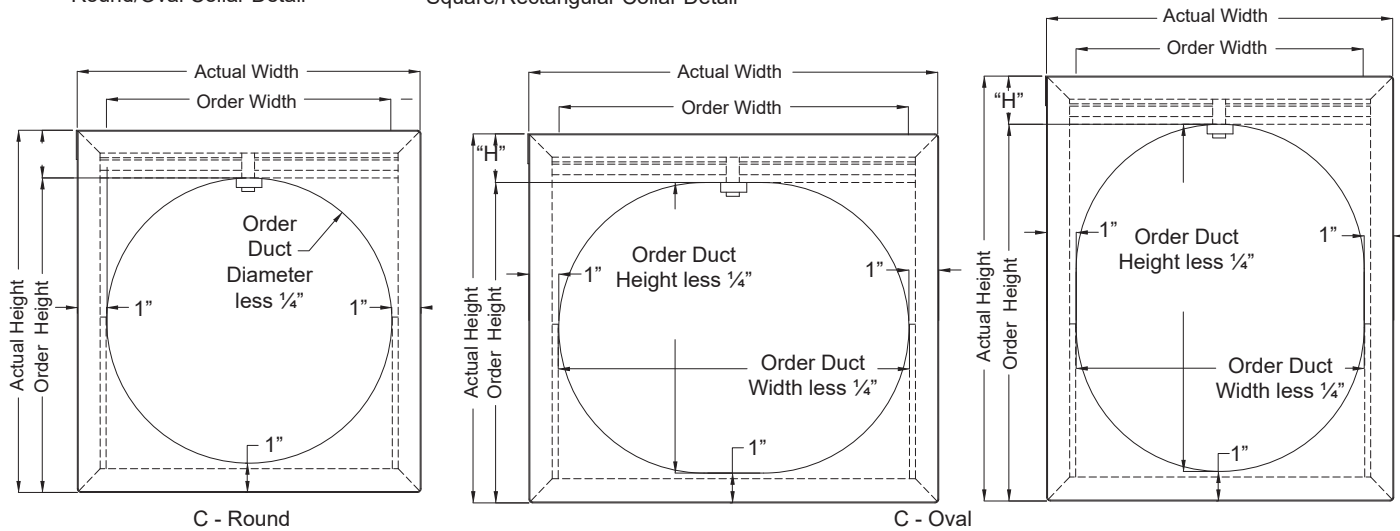

"H" = head height/blade stack height, see following tables, pages 9-11.

Note: Order Width & Height = OD of frame and do not include sleeve thickness

C-STYLE TRANSITION SIZING CHART

30SH: max single panel 48"W x 48"H, max panel in assembly 36"W x 36"H
30SV: max single panel 36"W x 36"H

30SH (Single Panel)

30SH (Multi Panel) & 30SV

30SV

Damper Sizing - C-Style Transition					
Duct Height	Assy. Height	# Panels High	Panel Height	"H"	# Blades
4"	-	1	7"	2"	4
5"	-	1	8"	2"	5
6"	-	1	9"	2"	5
7"	-	1	10"	2"	5
8"	-	1	11"	2"	6
9"	-	1	12"	2"	6
10"	-	1	13"	2"	6
11"	-	1	14"	2"	7
12"	-	1	15"	2"	7
13"	-	1	16"	2"	8
14"	-	1	17"	2"	8
15"	-	1	18"	2"	8
16"	-	1	19"	2"	9
17"	-	1	20"	2"	9
18"	-	1	22"	3"	10
19"	-	1	23"	3"	10
20"	-	1	24"	3"	11
21"	-	1	25"	3"	11
22"	-	1	26"	3"	11
23"	-	1	27"	3"	12
24"	-	1	28"	3"	12
25"	-	1	29"	3"	13
26"	-	1	30"	3"	13
27"	-	1	31"	3"	13
28"	-	1	33"	4"	14
29"	-	1	34"	4"	15
30"	-	1	35"	4"	15
31"	-	1	36"	4"	15
32"	-	1	37"	4"	16
33"	-	1	38"	4"	16
34"	-	1	39"	4"	17
35"	-	1	40"	4"	17
36"	-	1	41"	4"	17
37"	-	1	42"	4"	18
38"	-	1	43"	4"	18
39"	-	1	44"	4"	18
40"	-	1	46"	5"	19
41"	-	1	47"	5"	20
42"	-	1	48'	5"	20

Damper Sizing - C-Style Transition					
Duct Height	Assy. Height	# Panels High	Panel Height	"H"	# Blades
4"	-	-	7"	2"	4
5"	-	-	8"	2"	5
6"	-	-	9"	2"	5
7"	-	-	10"	2"	5
8"	-	-	11"	2"	6
9"	-	-	12"	2"	6
10"	-	-	13"	2"	6
11"	-	-	14"	2"	7
12"	-	-	15"	2"	7
13"	-	-	16"	2"	8
14"	-	-	17"	2"	8
15"	-	-	18"	2"	8
16"	-	-	19"	2"	9
17"	-	-	20"	2"	9
18"	-	-	22"	3"	10
19"	-	-	23"	3"	10
20"	-	-	24"	3"	11
21"	-	-	25"	3"	11
22"	-	-	26"	3"	11
23"	-	-	27"	3"	12
24"	-	-	28"	3"	12
25"	-	-	29"	3"	13
26"	-	-	30"	3"	13
27"	-	-	31"	3"	13
28"	-	-	33"	4"	14
29"	-	-	34"	4"	15
30"	-	-	35"	4"	15
31"	-	-	36"	4"	15
32"	35"	2	17.5"	2"	16
33"	36"	2	18"	2"	16
34"	37"	2	18.5"	2"	18
35"	38"	2	19"	2"	18
36"	39"	2	19.5"	2"	18
37"	40"	2	20"	2"	18
38"	42"	2	21"	4"	20
39"	43"	2	21.5"	3"	20
40"	44"	2	22"	3"	20
41"	45"	2	22.5"	3"	22
42"	46"	2	23"	3"	22
43'	47"	2	23.5"	3"	22

Damper Sizing - C-Style Transition					
Duct Height	Assy. Height	# Panels High	Panel Height	"H"	# Blades
44"	48"	2	24"	3"	22
45"	49"	2	24.5"	3"	22
46"	50"	2	25"	3"	22
47"	51"	2	25.5"	3"	22
48"	52"	2	26"	3"	24
49"	53"	2	26.5"	3"	24
50"	54"	2	27"	3"	24
51"	55"	2	27.5"	3"	24
52"	56"	2	28"	3"	24
53"	57"	2	28.5"	3"	26
54"	58"	2	29"	3"	26
55"	59"	2	29.5"	3"	26
56"	60"	2	30"	3"	26
57"	61"	2	30.5"	3"	26
58"	62"	2	31"	3"	26
59"	63"	2	31.5"	3"	26
60"	65"	2	32.5"	4"	28
61"	66"	2	33"	4"	28
62"	67"	2	33.5"	4"	28
63"	68"	2	34"	4"	30
64"	69"	2	34.5"	4"	30
65"	70"	2	35"	4"	30
66"	71"	2	35.5"	4"	30
67"	72"	2	36"	4"	30

C-STYLE TRANSITION SIZING CHART

30DH

Max Panel 24"W x 24"H
or 18"W x 36"H

Damper Sizing - C-Style Transition					
Duct Height	Assy. Height	# Panels High	Panel Height	"H"	# Blades
4"	-	1	7"	2"	8
5"	-	1	8"	2"	8
6"	-	1	9"	2"	9
7"	-	1	10"	2"	9
8"	-	1	12"	3"	10
9"	-	1	13"	3"	11
10"	-	1	14"	3"	11
11"	-	1	15"	3"	12
12"	-	1	16"	3"	12
13"	-	1	17"	3"	13
14"	-	1	18"	3"	13
15"	-	1	19"	3"	14
16"	-	1	20"	3"	14
17"	-	1	21"	3"	15
18"	-	1	22"	3"	15
19"	-	1	23"	3"	15
20"	-	1	25"	4"	17
21"	-	1	26"	4"	17
22"	-	1	27"	4"	18
23"	-	1	28"	4"	18
24"	-	1	29"	4"	19
25"	-	1	30"	4"	19
26"	-	1	31"	4"	20
27"	-	1	32"	4"	20
28"	-	1	34"	5"	21
29"	-	1	35"	5"	21
30"	-	1	36"	5"	21

30DV - Duct Height ≤ 36 inches

Max 36"W x 36"H single panel,
Max 18"W x 36"H panel in assembly

Damper Sizing - C-Style Transition					
Duct Height	Assy. Height	# Panels High	Panel Height	"H"	# Blades
4"	-	1	7"	2"	5
5"	-	1	8"	2"	5
6"	-	1	9"	2"	6
7"	-	1	10"	2"	6
8"	-	1	11"	2"	6
9"	-	1	12"	2"	7
10"	-	1	13"	2"	7
11"	-	1	14"	2"	8
12"	-	1	15"	2"	8
13"	-	1	16"	2"	8
14"	-	1	17"	2"	9
15"	-	1	18"	2"	9
16"	-	1	19"	2"	9
17"	-	1	20"	2"	10
18"	-	1	22"	3"	11
19"	-	1	23"	3"	11
20"	-	1	24"	3"	12
21"	-	1	25"	3"	12
22"	-	1	26"	3"	13
23"	-	1	27"	3"	13
24"	-	1	28"	3"	13
25"	-	1	30"	3"	14
26"	-	1	31"	3"	15
27"	-	1	32"	3"	15
28"	-	1	33"	3"	15
29"	-	1	34"	4"	16
30"	-	1	35"	4"	16
31"	-	1	36"	4"	17

C-STYLE TRANSITION SIZING CHART**30DV** - Duct Height > 36 inches

Max 24"W x 24"H panel in assembly

Damper Sizing - C-Style Transition					
Duct Height	Assy. Height	# Panels High	Panel Height	"H"	# Blades
32"	37"	2	18.5"	4"	18
33"	38"	2	19"	4"	18
34"	39"	2	19.5"	4"	20
35"	40"	2	20"	4"	20
36"	41"	2	20.5"	4"	20
37"	42"	2	21"	4"	20
38"	43"	2	21.5"	4"	22
39"	44"	2	22"	4"	22
40"	45"	2	22.5"	4"	22
41"	46"	2	23"	4"	22
42"	47"	2	23.5"	4"	24
43"	48"	2	24"	4"	24
44"	49"	3	16"	4"	27
45"	50"	3	17"	4"	27
46"	51"	3	17.0"	4"	27
47"	52"	3	17.3"	4"	27
48"	53"	3	18"	4"	27
49"	54"	3	18.0"	4"	27
50"	55"	2	18.3"	4"	27
51"	56"	3	19"	4"	27
52"	57"	3	19.0"	4"	27
53"	58"	3	19.3"	4"	30
54"	59"	3	20"	4"	30
55"	60"	3	20.0"	4"	30
56"	61"	3	20.3"	4"	30
57"	62"	3	20.7"	4"	30
58"	63"	3	21.0"	4"	30
59"	64"	3	21.3"	4"	33
60"	65"	3	21.7"	4"	33
61"	66"	3	22"	4"	33
62"	67"	3	22"	4"	33
63"	68"	3	22.7"	4"	33
64"	69"	3	23"	4"	33
65"	70"	3	23"	4"	36
66"	71"	3	23.7"	4"	36
67"	72"	3	24"	4"	36

Multiple Panel / Multiple Ship Section Details

1. Damper assemblies ordered without factory mounted sleeves typically ship in individual panels to be field assembled.
2. Damper assemblies ordered with factory mounted sleeves ship assembled. Due to shipping limitations, large damper assemblies may require more than one ship section. If more than one ship section is required, each ship section will be individually sleeved.
3. Mullion stiffeners are required per the illustrations below. The details shown are typical for all mullions in the same direction for that mounting orientation. For ship loose panels, mullion stiffeners are typically not provided by the factory. For single ship section sleeved dampers, mullion stiffeners will ship assembled as required. For multiple ship section sleeved dampers, the mullion stiffeners will ship assembled as required within each sleeved section. Mullion stiffeners are not required between the sleeved sections.
4. For vertical static installations where the wall/floor opening is larger than the approved maximum assembly size, the approved mullion illustrated on pages 8 and 9 of II-FD-3 must separate the opening into smaller openings. This is approved for static installations only. For installations not covered by the method, the Local Authority Having Jurisdiction (LAHJ) must approve a mullion to separate the large openings into smaller openings.
5. Mullion details specified are based on the fire ratings qualifications tests. The user is responsible for additional structural supports of multiple section dampers when required by elevated air pressure differential in the closed position and in some cases, seismic loading.

